

5

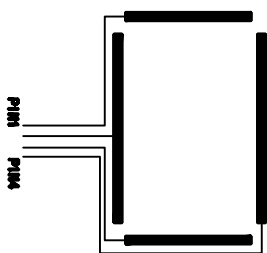

DETAIL-B

4

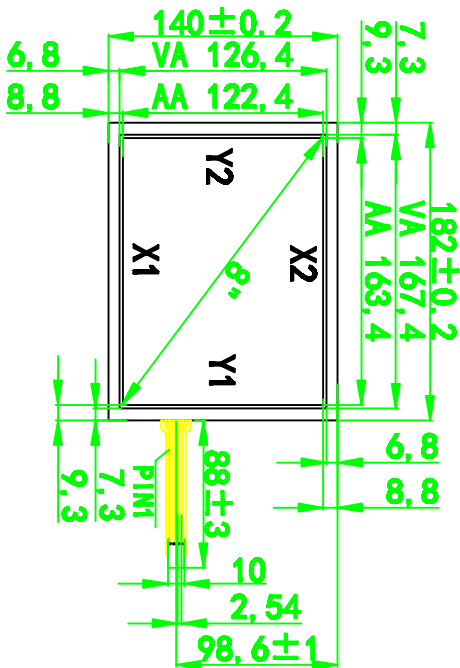
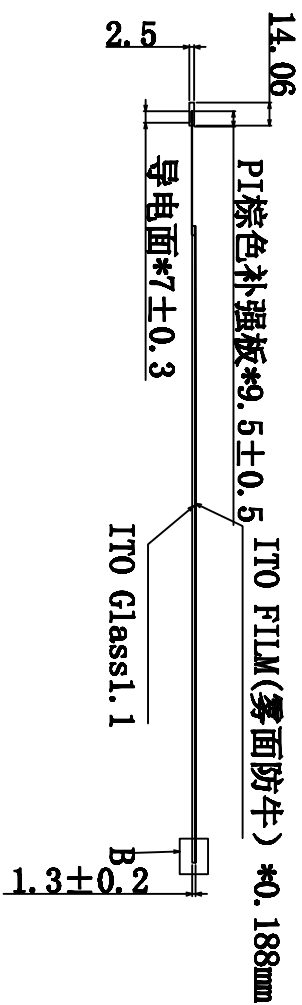

2

**Instruction:**

1. Type: Film to Glass
2. Operating Voltage: 3~7 V
3. Response Time: ≤10ms
4. Storage Temperature: -20°C~+70 °C
5. Operation Temperature/humidity: -10 °C~+60°C/ 20%~90%
6. Hitting Life: >10,000,000 Times .250gf Force;
7. Hitting Life: >1,000,000 Times 250gf Force;
8. Connect Material: FPO+PIN

1

9. Film Thickness: 0.188mm
10. Glass Thickness: 1.1mm
11. Light transmission: ≥78%
12. Force: 100g or less
13. Linearity: ≤1.5%
14. Insulation: ≥20M Ω
15. Surface Hardness: ≥3H (pencil)
16. 未标注公差为±0.2mm

paullu@citouch.cn

MODEL NO.	CJ080A4B01	UNIT:	MM
DRAWN:		TOLERANCE:	±0.3
DATE:	15/11/04	SCALE:	1:1
VERSION:	1.0	REV:	